

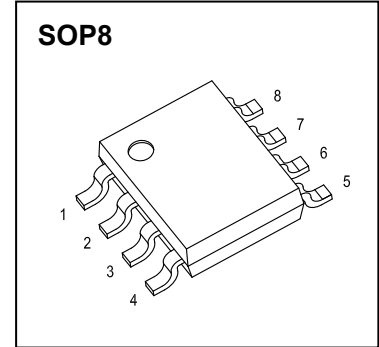

## SOP8 Plastic-Encapsulate MOSFETS

### ZSQ4953 P-Channel Power MOSFET

$V_{(BR)DSS}$	$R_{DS(on)}$ TYP	$I_D$
-30V	41mΩ@-10V	-5A
	57mΩ@-4.5V	



#### FEATURE

- Surface Mount Package
- Super High Density Cell Design for Extremely Low  $R_{DS(ON)}$

#### MARKING:

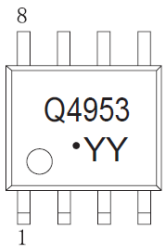

Q4953= Device code  
 YY=Code  
 Solid dot = Pin1 indicator  
 Solid dot=Green molding compound device,  
 if none,the normal device.

#### Equivalent Circuit

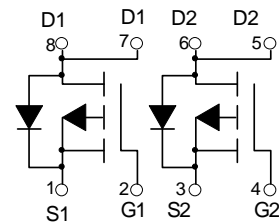

#### ABSOLUTE MAXIMUM RATINGS ( $T_a=25^\circ\text{C}$ unless otherwise noted)

Parameter	Symbol	Value	Unit
Drain-Source Voltage	$V_{DS}$	-30	V
Gate-Source Voltage	$V_{GS}$	$\pm 20$	V
Continuous Drain Current	$I_D$ <sup>①</sup>	-5	A
Pulsed Drain Current	$I_{DM}$ <sup>②</sup>	-20	A
Single Pulsed Avalanche Energy	$E_{AS}$ <sup>③</sup>	20	mJ
Maximum Power Dissipation	$P_D$ <sup>④</sup>	2.0	W
Thermal Resistance from Junction to Ambient	$R_{\theta JA}$ <sup>⑤</sup>	62.5	$^\circ\text{C/W}$
Operating Junction and Storage Temperature Range	$T_J, T_{stg}$ <sup>⑥</sup>	-55~+150	$^\circ\text{C}$

# MOSFET ELECTRICAL CHARACTERISTICS

$T_a=25^\circ\text{C}$  unless otherwise specified

Parameter	Symbol	Test Condition	Min	Typ	Max	Unit
<b>Off characteristics</b>						
Drain-source breakdown voltage	$V_{(BR)DSS}$	$V_{GS} = 0V, I_D = -250\mu A$	-30			V
Zero gate voltage drain current	$I_{DSS}$	$V_{DS} = -30V, V_{GS} = 0V$	$T_J = 25^\circ\text{C}$		-1	$\mu A$
			$T_J = 125^\circ\text{C}$		-200	
Gate-body leakage current	$I_{GSS}$	$V_{DS} = 0V, V_{GS} = \pm 20V$			$\pm 100$	nA
<b>On characteristics</b> <sup>④</sup>						
Gate-threshold voltage	$V_{GS(th)}$	$V_{DS} = V_{GS}, I_D = -250\mu A$	-1.0	-1.4	-2.0	V
Static drain-source on-state resistance	$R_{DS(on)}$	$V_{GS} = -10V, I_D = -4.9A$		41	60	m $\Omega$
		$V_{GS} = -4.5V, I_D = -3.7A$		57	90	m $\Omega$
<b>Dynamic characteristics</b> <sup>④ ⑤</sup>						
Input capacitance	$C_{iss}$	$V_{DS} = -15V, V_{GS} = 0V, f = 1MHz$		615		pF
Output capacitance	$C_{oss}$			65		
Reverse transfer capacitance	$C_{rss}$			57		
<b>Switching characteristics</b> <sup>④ ⑤</sup>						
Turn-on delay time	$t_{d(on)}$	$V_{DS} = -15V, V_{GS} = -10V, R_L = 3.6\Omega, R_G = 3\Omega$		8.6		ns
Turn-on rise time	$t_r$			5.0		
Turn-off delay time	$t_{d(off)}$			28.2		
Turn-off fall time	$t_f$			13.5		
<b>Drain-Source Diode Characteristics</b>						
Drain-source diode forward voltage	$V_{SD}$ <sup>④</sup>	$V_{GS} = 0V, I_S = -1.7A$			-1.2	V
Continuous drain-source diode forward current	$I_S$ <sup>①</sup>				-5	A
Pulsed drain-source diode forward current	$I_{SM}$ <sup>②</sup>				-20	A

Notes:

- $T_C=25^\circ\text{C}$  Limited only by maximum temperature allowed.
- $P_W \leq 10\mu s$ , Duty cycle  $\leq 1\%$ .
- EAS condition:  $V_{DD} = -30V, V_{GS} = -10V, L = 0.5mH, R_g = 25\Omega$  Starting  $T_J = 25^\circ\text{C}$ .
- Pulse Test : Pulse Width  $\leq 300\mu s$ , duty cycle  $\leq 2\%$ .
- Guaranteed by design, not subject to production.
- The value of  $R_{\theta JA}$  is measured with the device mounted on 1 in<sup>2</sup> FR-4 board with 2oz. Copper, in a still air environment with  $T_a = 25^\circ\text{C}, t \leq 10\text{sec}$ . For a dual device with one active die.

# Typical Characteristics

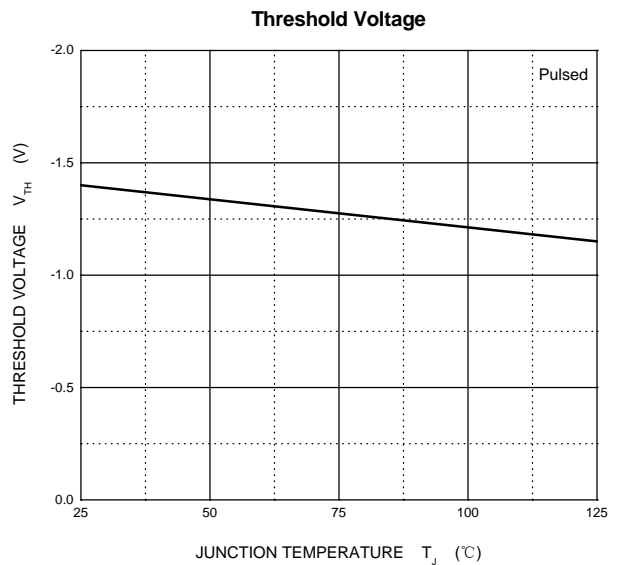
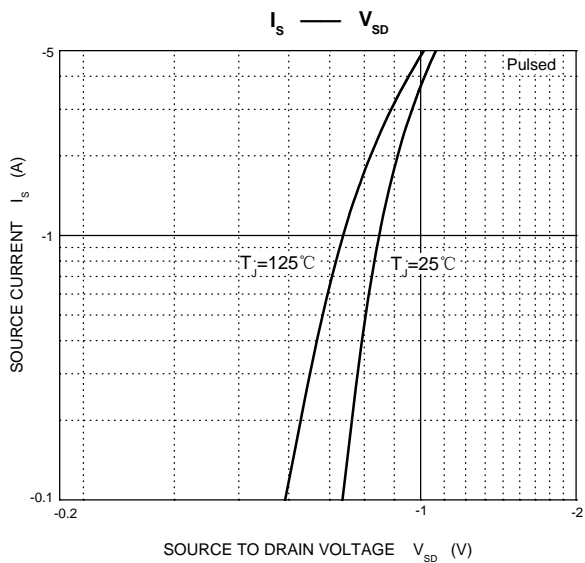
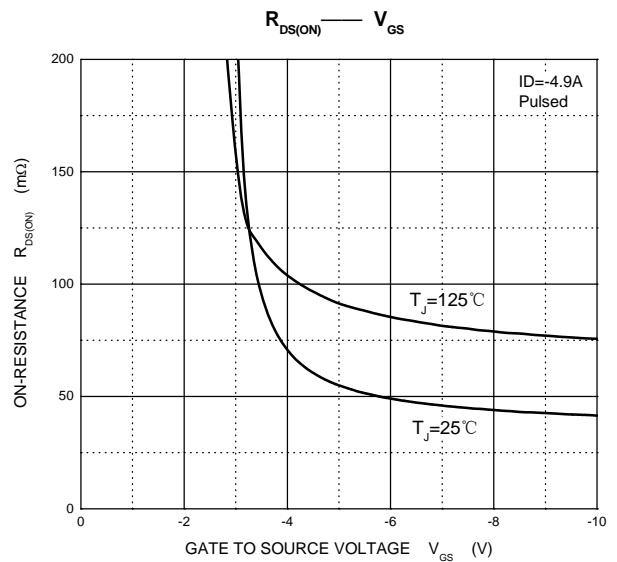
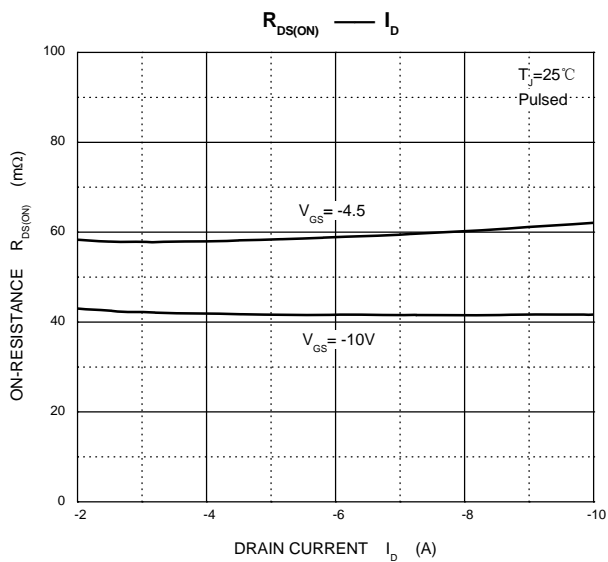
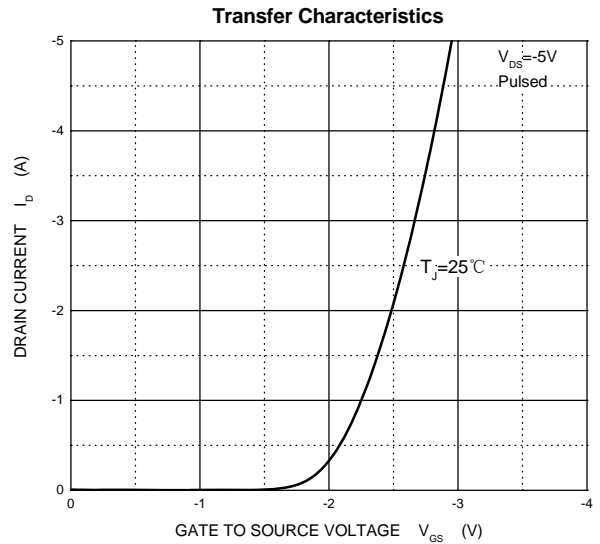
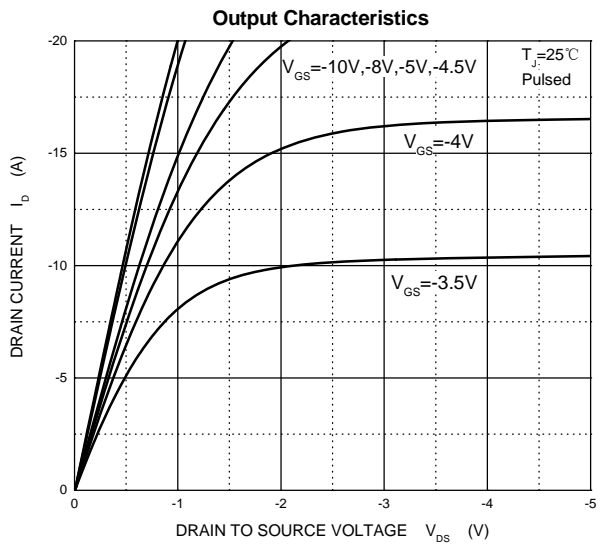

# Typical Characteristics

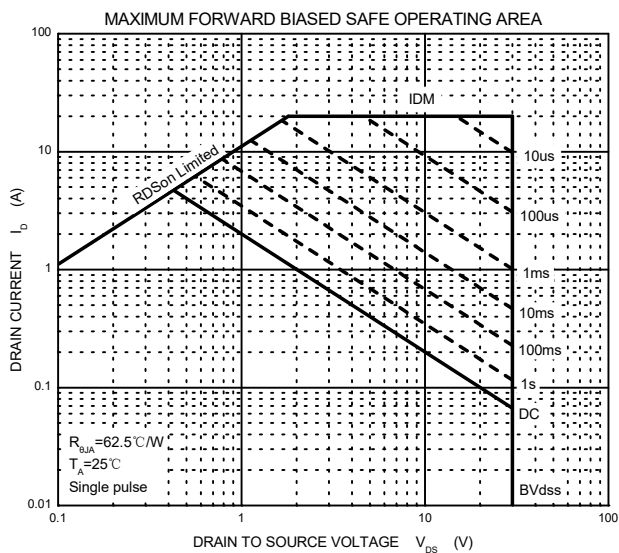
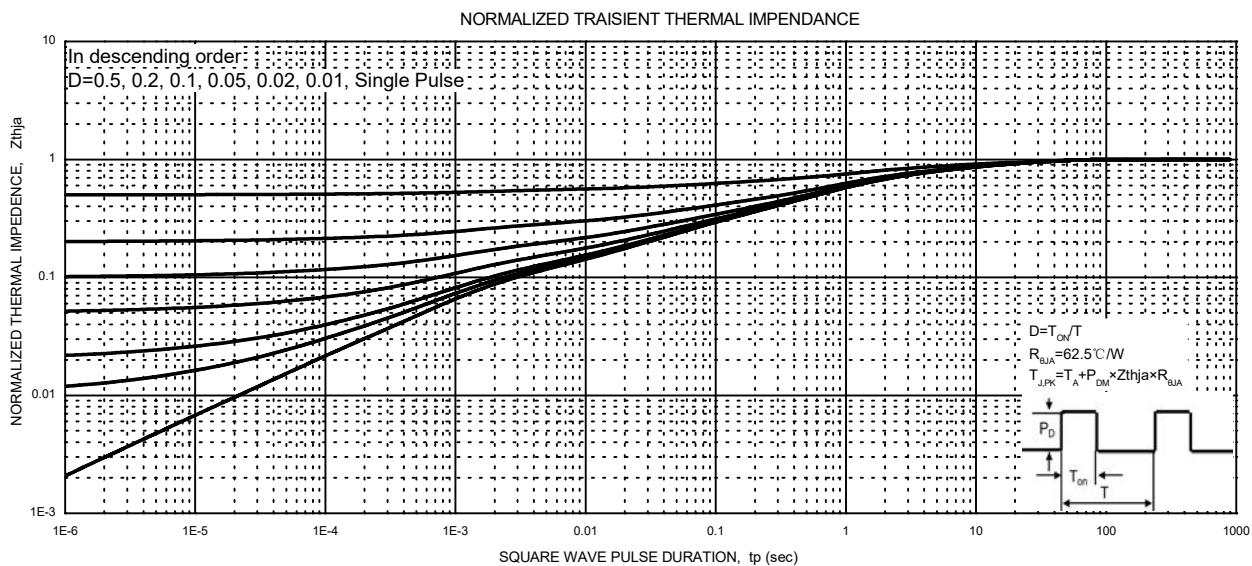

## SOP8 Package Outline Dimensions

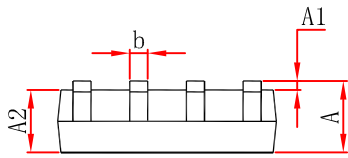
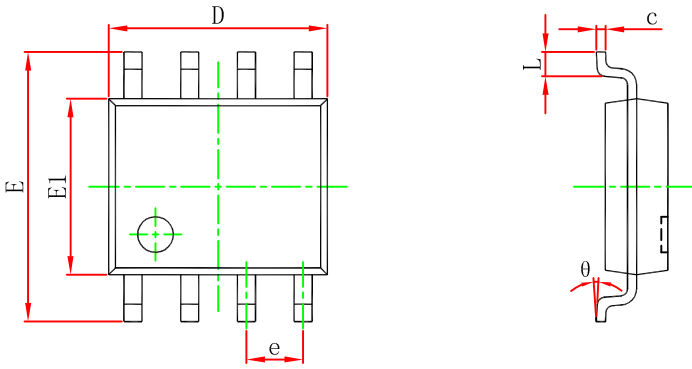

Symbol	Dimensions In Millimeters		Dimensions In Inches	
	Min	Max	Min	Max
A	1.450	1.750	0.053	0.069
A1	0.100	0.250	0.004	0.010
A2	1.350	1.550	0.053	0.061
b	0.330	0.510	0.013	0.020
c	0.170	0.250	0.007	0.010
D	4.700	5.100	0.185	0.201
e	1.270 (BSC)		0.050 (BSC)	
E	5.800	6.200	0.228	0.244
E1	3.800	4.000	0.150	0.157
L	0.400	1.270	0.016	0.050
θ	0°	8°	0°	8°

## SOP8 Suggested Pad Layout

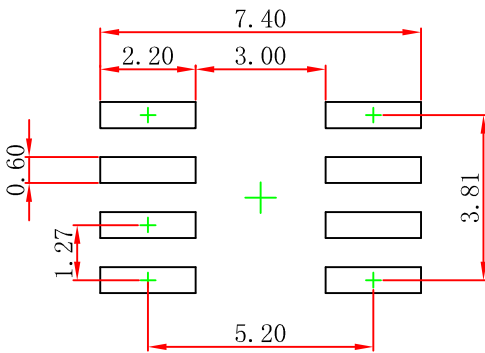

**Note:**

1. Controlling dimension: in millimeters.
2. General tolerance:  $\pm 0.05\text{mm}$ .
3. The pad layout is for reference purposes only.

# SOP8 Tape and Reel

## SOP8 Embossed Carrier Tape

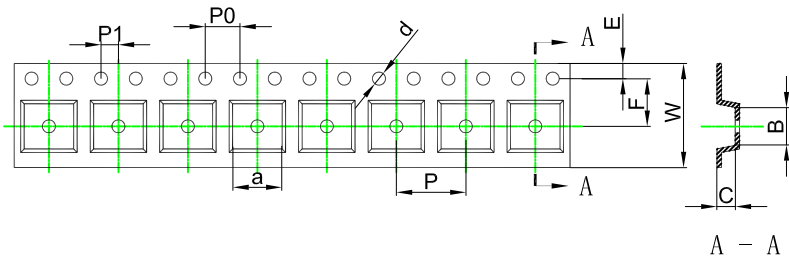

### Packaging Description:

SOP8 parts are shipped in tape. The carrier tape is made from a dissipative (carbon filled) polycarbonate resin. The cover tape is a multilayer film (Heat Activated Adhesive in nature) primarily composed of polyester film, adhesive layer, sealant, and anti-static sprayed agent. These reeled parts in standard option are shipped with 4,000 units per 13" or 33cm diameter reel. The reels are clear in color and is made of polystyrene plastic (anti-static coated).

ALL DIM IN mm

Dimensions are in millimeter										
Pkg type	a	B	C	d	E	F	P0	P	P1	W
SOP8	6.40	5.40	2.10	Ø1.50	1.75	5.50	4.00	8.00	2.00	12.00

## SOP8 Tape Leader and Trailer

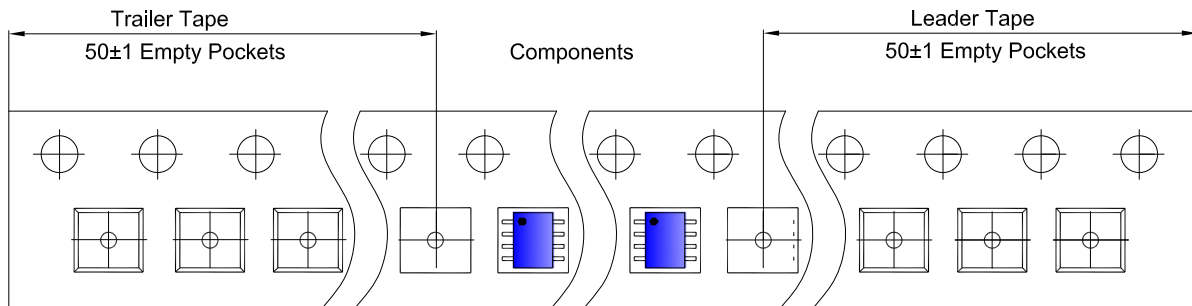

## SOP8 Reel

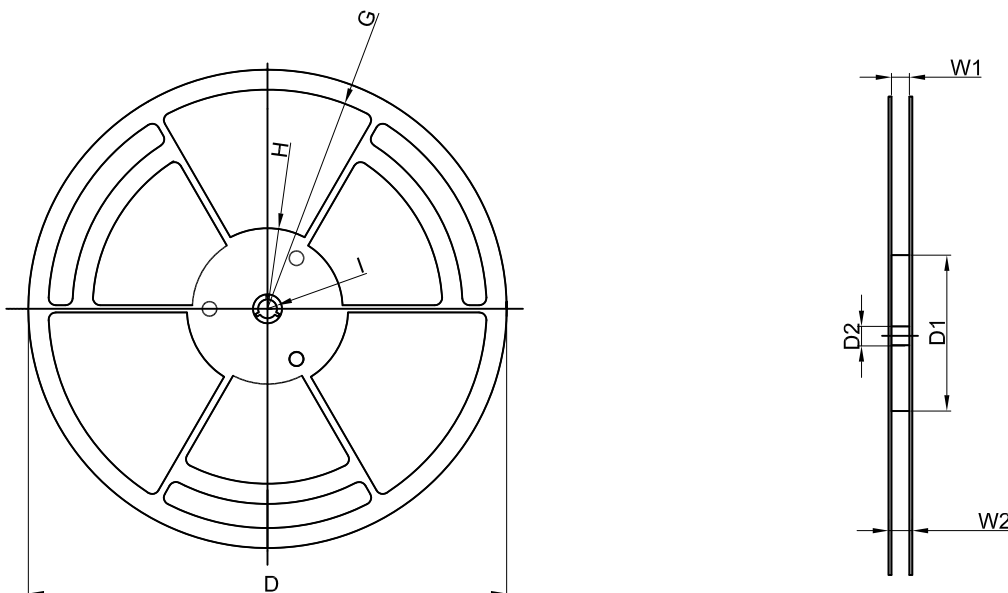

Dimensions are in millimeter								
Reel Option	D	D1	D2	G	H	I	W1	W2
13" Dia	Ø330.00	100.00	13.00	R151.00	R56.00	R6.50	12.40	17.60

REEL	Reel Size	Box	Box Size(mm)	Carton	Carton Size(mm)	G.W.(kg)
4,000 pcs	13 inch	8,000 pcs	360×360×65	64,000 pcs	565×380×390	