



1A LOW DROPOUT LINEAR REGULATOR

ZSA1117B-XXX

FEATURES

- 🔌 Low Dropout Voltage: 1.15V at 1A Output Current
- 🔌 Trimmed Current Limit
- 🔌 On-Chip Thermal Shutdown
- 🔌 Three-Terminal Adjustable or Fixed 1.8V, 2.5V, 3.3V, 5V
- 🔌 Operation Junction Temperature: -40 to 125°C

GENERAL DESCRIPTION

The ZSA1117B-XXX is a series of low dropout three-terminal regulators with a dropout of 1.15V at 1A output current.

The ZSA1117B-XXX series provides current limiting and thermal shutdown. Its circuit includes a trimmed bandage. reference to assure output voltage accuracy to be within 1.5%. Current limit is trimmed to ensure specified. output current and controlled short-circuit current. On-chip thermal shutdown provides protection against any combination of overload and ambient temperature that would create excessive junction temperature.

The ZSA1117B-XXX has an adjustable version, that can provide the output voltage from 1.25V to 5V with only 2 external resistors.

SOT-89-3L

- 1. ADJ/GND
- 2. OUTPUT
- 3. IN

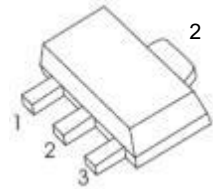

APPLICATIONS

- 🔌 PC Motherboard
- 🔌 LCD Monitor
- 🔌 Graphic Card
- 🔌 DVD-Video Player
- 🔌 NIC/Switch
- 🔌 Telecom Modem
- 🔌 ADSL Modem
- 🔌 Printer and other peripheral Equipment

MARKING



"A1117B": Device serial number.

"X.X": Output voltage, for example, if $V_{OUT} = 3.0V$, "X.X" = 3.0.

"YY": Code composed of two uppercase letters, indicates weekly record information of production.

ORDERING INFORMATION

Package	Operating Junction Temperature Range	Part NO.
SOT-89-3L	-40 to 125°C	ZSA1117B-ADJ
		ZSA1117B-1.8
		ZSA1117B-2.5
		ZSA1117B-3.3
		ZSA1117B-5.0

ABSOLUTE MAXIMUM RATINGS

($T_A = 25^\circ\text{C}$, unless otherwise specified)

Parameter	Symbol	Value	Unit
Input Voltage	V_i	20	V
Thermal Resistance from Junction to Ambient	$R_{\theta JA}$	250	$^\circ\text{C}/\text{W}$
Operating Ambient Temperature	T_A	-40~+85	$^\circ\text{C}$
Operating Junction Temperature	T_j	-40~+125	$^\circ\text{C}$
Storage Temperature	T_{stg}	-40~+125	$^\circ\text{C}$
Soldering Temperature & Time	T_{solder}	260 $^\circ\text{C}$, 10s	
ESD Voltage (Machine Model)	V_{ESD}	400	V

Note: Stresses greater than those listed under "Absolute Maximum Ratings" may cause permanent damage to the device. These are stress ratings only, and functional of the device at these or any other conditions beyond those indicated under "Recommended Operating Conditions" is not implied. Exposure to "Absolute Maximum Ratings" for extended periods may affect device reliability.

RECOMMENDED OPERATING CONDITIONS

Parameter	Symbol	Value	Unit
Input Voltage	V_i	15	V
Operating Junction Temperature	T_j	-40~+125	$^\circ\text{C}$

ELECTRICAL CHARACTERISTICS

($V_{IN} \leq 10V$, $T_J = 25^\circ C$, unless otherwise specified)

Parameter	Symbol	Part No.	Test Conditions	Min	Typ	Max	Unit
Reference Voltage	V_{IROC}	ZSA1117B-ADJ	$I_{OUT}=10mA$, $V_{IN}=3.23$	1.231	1.250	1.269	V
			$10mA \leq I_{OUT} \leq 1A$, $2.75V \leq V_{IN} - V_{OUT} \leq 13.25V$	1.225	1.250	1.275	
Output Voltage	V_O	ZSA1117B-1.8	$I_{OUT}=10mA$, $V_{IN}=3.8V$	1.773	1.8	1.827	V
			$10mA \leq I_{OUT} \leq 1A$, $3.3V \leq V_{IN} \leq 12V$	1.764	1.8	1.836	
		ZSA1117B-2.5	$I_{OUT}=10mA$, $V_{IN}=4.5V$	2.463	2.5	2.538	V
			$10mA \leq I_{OUT} \leq 1A$, $4V \leq V_{IN} \leq 12V$	2.450	2.5	2.550	
		ZSA1117B-3.3	$I_{OUT}=10mA$, $V_{IN}=5.3V$	3.251	3.3	3.350	V
			$10mA \leq I_{OUT} \leq 1A$, $4.8V \leq V_{IN} \leq 12V$	3.234	3.3	3.366	
		ZSA1117B-5.0	$I_{OUT}=10mA$, $V_{IN}=7.0V$	4.925	5.0	5.075	V
			$10mA \leq I_{OUT} \leq 1A$, $6.5V \leq V_{IN} \leq 12V$	4.9	5.0	5.1	
Line Regulation	LNR	ZSA1117B-ADJ	$I_{OUT}=10mA$, $1.5V \leq V_{IN} - V_{OUT} \leq 12V$		0.035	0.2	mV
		ZSA1117B-1.8	$I_{OUT}=10mA$, $1.5V \leq V_{IN} - V_{OUT} \leq 10.2V$		1	7	
		ZSA1117B-2.5	$I_{OUT}=10mA$, $1.5V \leq V_{IN} - V_{OUT} \leq 9.5V$		1	7	
		ZSA1117B-3.3	$I_{OUT}=10mA$, $1.5V \leq V_{IN} - V_{OUT} \leq 8.7V$		1	7	
		ZSA1117B-5.0	$I_{OUT}=10mA$, $1.5V \leq V_{IN} - V_{OUT} \leq 7V$		1	10	
Load Regulation	LDR	ZSA1117B-ADJ	$V_{IN} - V_{OUT} = 1.5V$, $10mA \leq I_{OUT} \leq 1A$		0.2	0.4	mV
		ZSA1117B-1.8				7.2	
		ZSA1117B-2.5				10	
		ZSA1117B-3.3				13.2	
		ZSA1117B-5.0				20	
Dropout Voltage	V_D		$\Delta V_{REF}=1\%$, $I_{OUT}=1.0A$			1.3	V
Current Limit	I_{limit}		$V_{IN} - V_{OUT}=2V$	1			A
Adjust Pin Current	I_{ADJ}		$I_{OUT}=10mA$ (ADJ only)		60	120	μA
Adjust Pin Current Change	ΔI_{ADJ}		$1.5V=V_{IN} - V_{OUT}=12V$, $I_{OUT}=10mA$ (ADJ only)		1.7	5	μA
Minimum Load Current	I_L		$V_{IN} = 5V$, $V_{ADJ} = 0V$		5	7	mA
Quiescent Current	I_q		$V_{IN} = V_{OUT} + 1.25V$ (ADJ except)		5	10	mA
Ripple Rejection	RR		$f=120Hz$, $C_{OUT}=22\mu F$ Tantalum, $V_{IN}-V_{OUT}=3V$, $I_{OUT}=1A$	60	75		dB
Temperature Stability					0.5		%
Long-Term Stability			$T_A=125^\circ C$, 1000hrs		0.3		%
RMS Output Noise (% of VOUT)			$T_A=25^\circ C$, $10Hz \leq f \leq 10kHz$		0.003		%
Thermal Shutdown Hysteresis					25		$^\circ C$

* With package soldering to copper area over backside ground plane or internal power plane $R_{\theta JA}$ can vary from $46^\circ C/W$ to $>90^\circ C/W$ depending on mounting technique and the size of the copper area

FUNCTIONAL BLOCK DIAGRAM

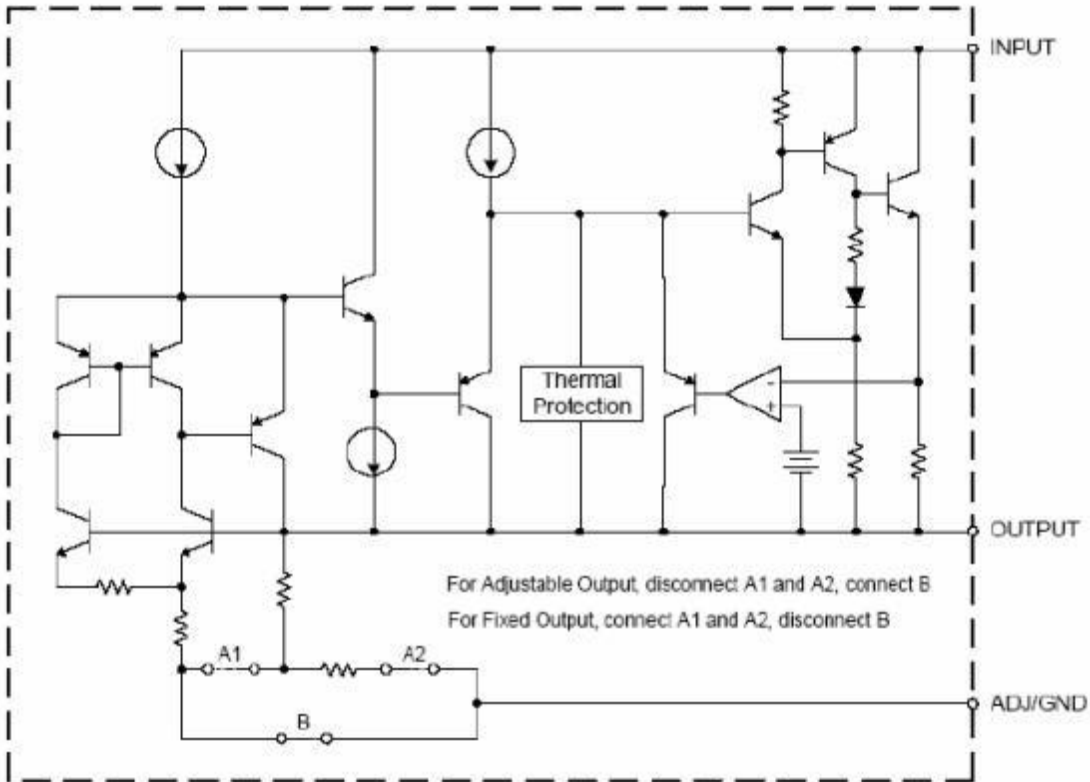

TYPICAL APPLICATION CIRCUIT

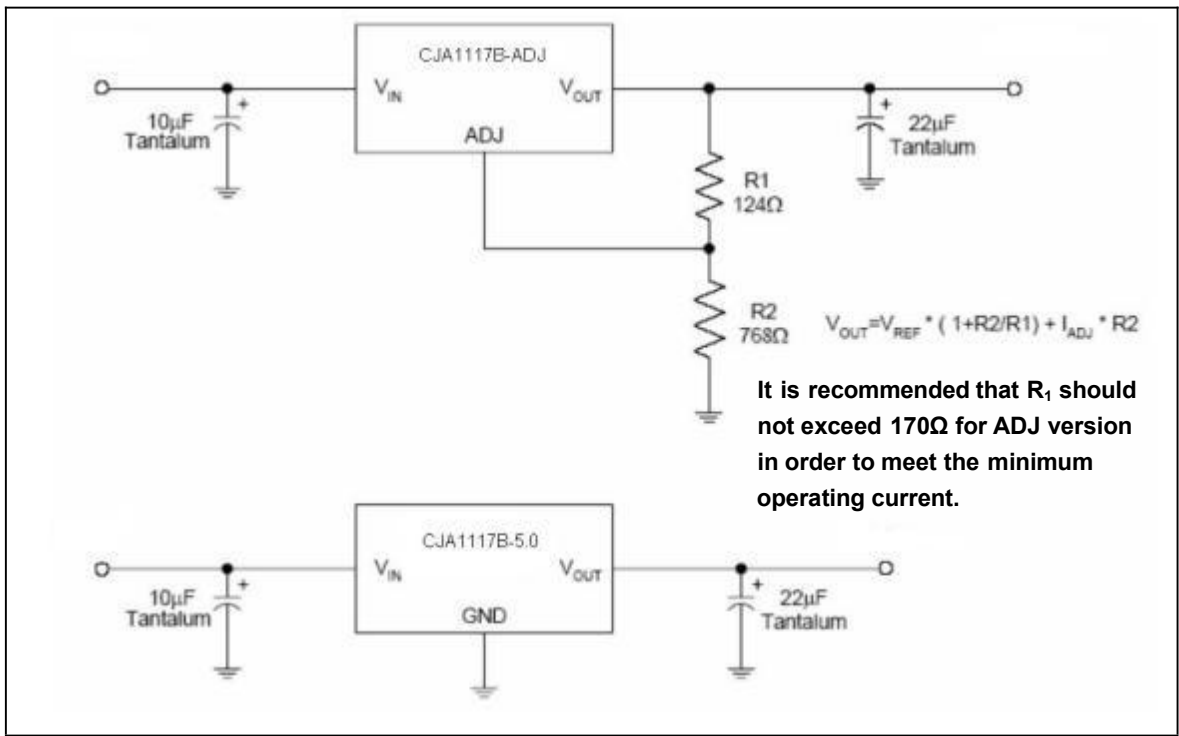

Typical Characteristics

Dropout Voltage vs. Output Current

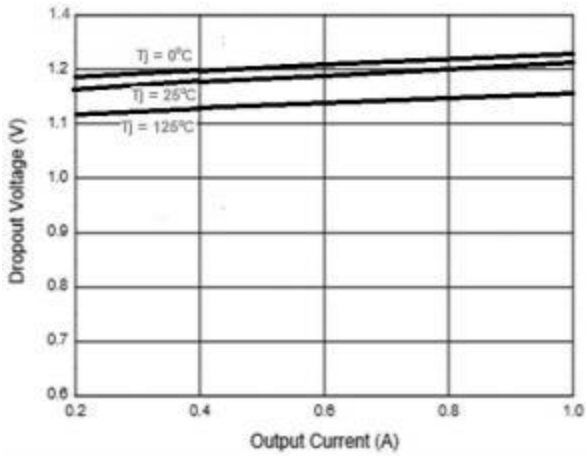

Dropout Voltage vs. Junction Temperature

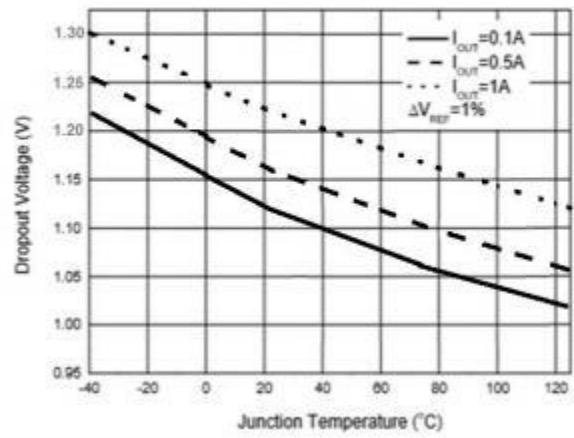

Load Regulation vs. Junction Temperature

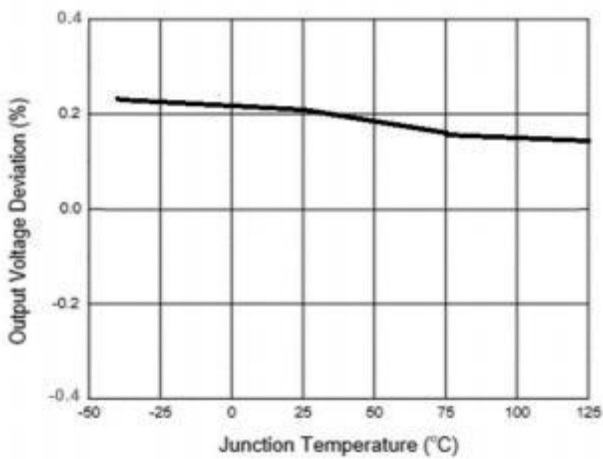

Reference Voltage vs. Junction Temperature

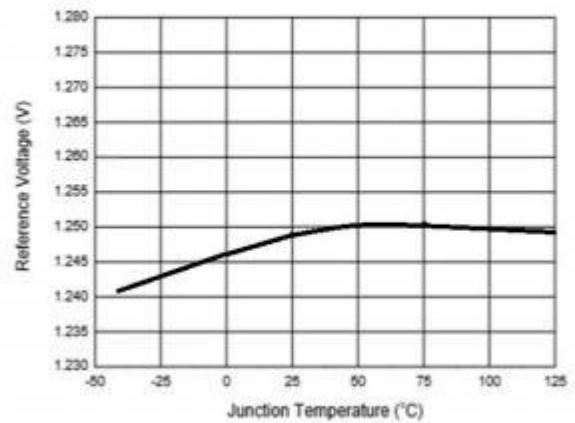

Output Voltage vs. Junction Temperature

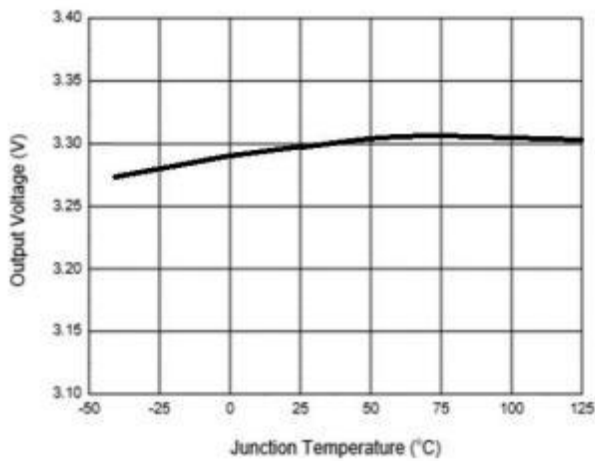

Minimum Load Current vs. Junction Temperature

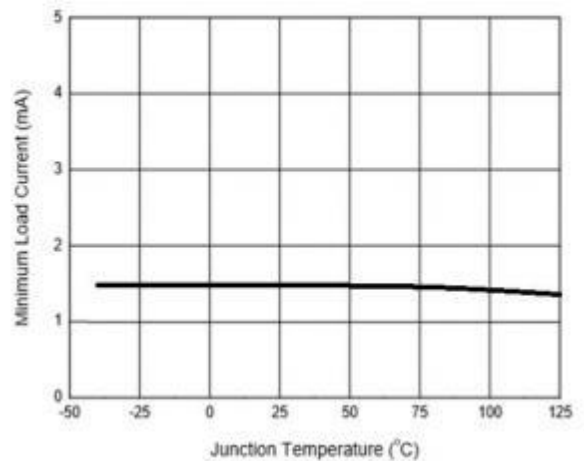

Typical Characteristics

Adjust Pin Current vs. Junction Temperature

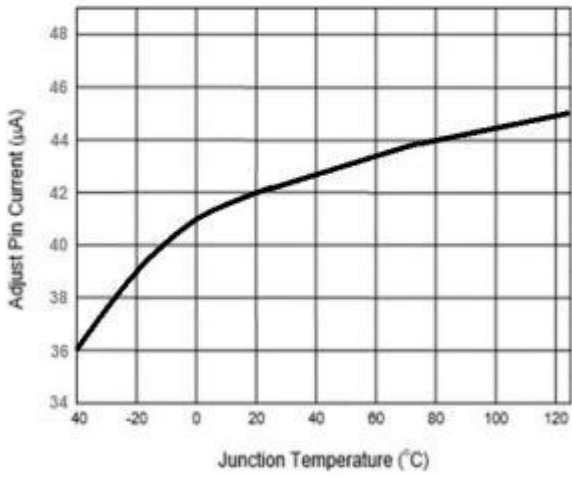

Short-circuit Current vs. Junction Temperature

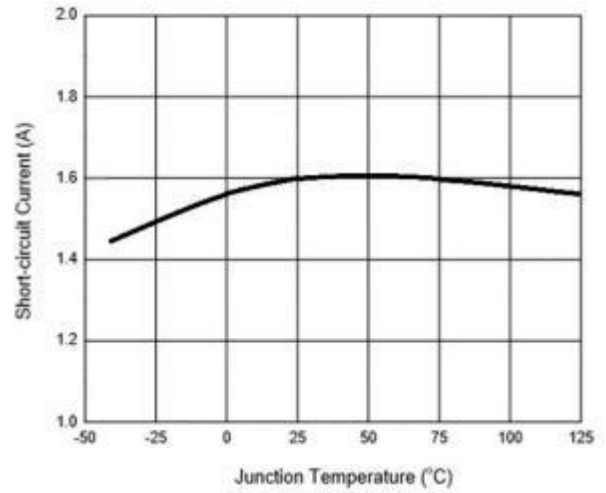

PSRR Vs. Frequency

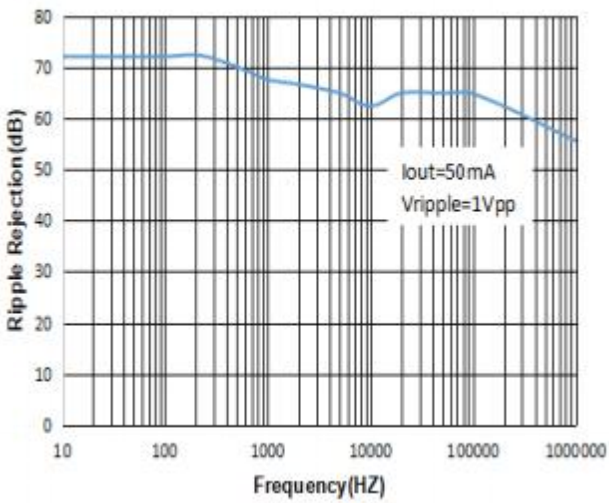

SOT-89-3L Package Outline Dimensions

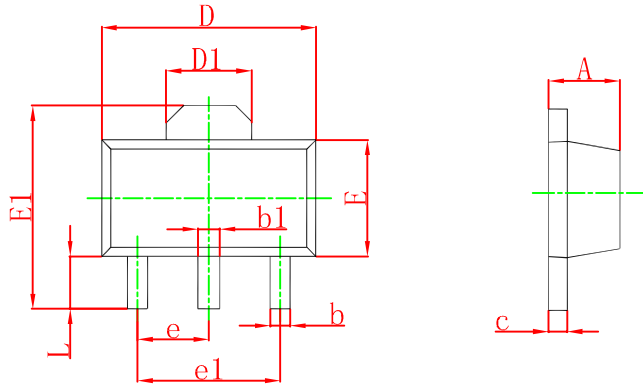

Symbol	Dimensions In Millimeters		Dimensions In Inches	
	Min	Max	Min	Max
A	1.400	1.600	0.055	0.063
b	0.320	0.520	0.013	0.020
b1	0.400	0.580	0.016	0.023
c	0.350	0.440	0.014	0.017
D	4.400	4.600	0.173	0.181
D1	1.550 REF.		0.061 REF.	
E	2.300	2.600	0.091	0.102
E1	3.940	4.250	0.155	0.167
e	1.500 TYP.		0.060 TYP.	
e1	3.000 TYP.		0.118 TYP.	
L	0.900	1.200	0.035	0.047

SOT-89-3L Suggested Pad Layout

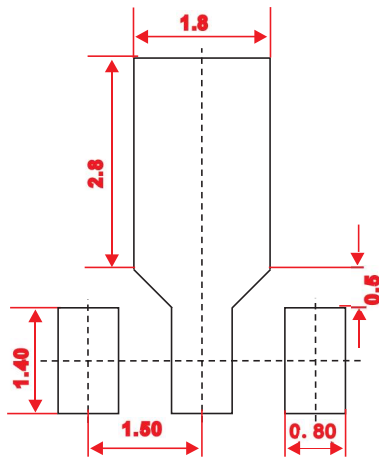

Note:

1. Controlling dimension : in millimeters.
2. General tolerance: $\pm 0.05\text{mm}$.
3. The pad layout is for reference purposes only.

SOT-89-3L Tape and Reel

SOT-89-3L Embossed Carrier Tape

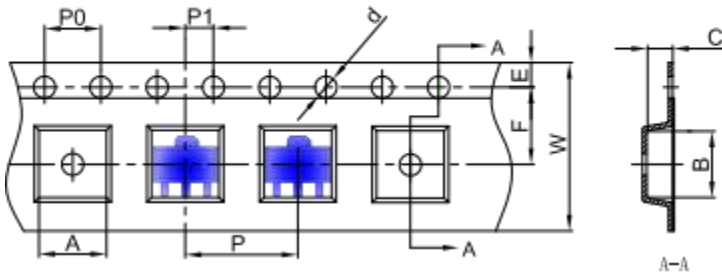

Packaging Description:

SOT-89-3L parts are shipped in tape. The carrier tape is made from a dissipative (carbon filled) polycarbonate resin. The cover tape is a multilayer film (Heat Activated Adhesive in nature) primarily composed of polyester film, adhesive layer, sealant, and anti-static sprayed agent. These reeled parts in standard option are shipped with 1,000 units per 7" or 18.0 cm diameter reel. The reels are clear in color and is made of polystyrene plastic (anti-static coated).

Dimensions are in millimeter										
Pkg type	A	B	C	d	E	F	P0	P	P1	W
SOT-89-3L	4.85	4.45	1.85	Ø1.50	1.75	5.50	4.00	8.00	2.00	12.00

SOT-89-3L Tape Leader and Trailer

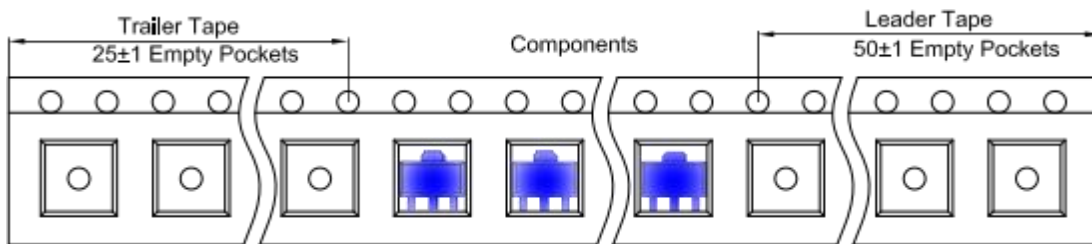

SOT-89-3L Reel

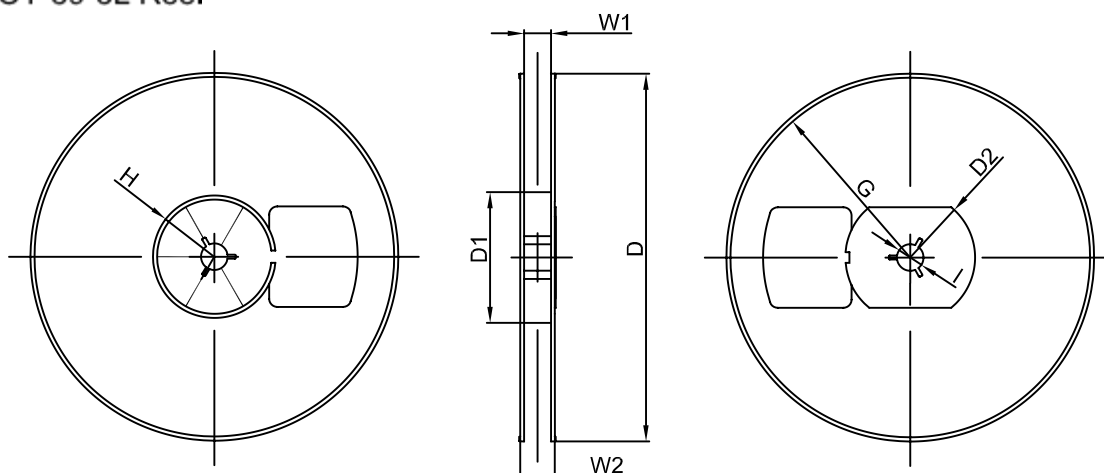

Dimensions are in millimeter								
Reel Option	D	D1	D2	G	H	I	W1	W2
7" Dia	Ø180.00	60.00	R32.00	R86.50	R30.00	Ø13.00	13.20	16.50

REEL	Reel Size	Box	Box Size(mm)	Carton	Carton Size(mm)	G.W.(kg)
1000 pcs	7 Inch	10,000 pcs	203×203×195	40,000 pcs	438×438×220	

DISCLAIMER

IMPORTANT NOTICE, PLEASE READ CAREFULLY

The information in this data sheet is intended to describe the operation and characteristics of our products. ZS has the right to make any modification, enhancement, improvement, correction or other changes to any content in this data sheet, including but not limited to specification parameters, circuit design and application information, without prior notice.

Any person who purchases or uses ZS products for design shall: 1. Select products suitable for circuit application and design; 2. Design, verify and test the rationality of circuit design; 3. Procedures to ensure that the design complies with relevant laws and regulations and the requirements of such laws and regulations. ZS makes no warranty or representation as to the accuracy or completeness of the information contained in this data sheet and assumes no responsibility for the application or use of any of the products described in this data sheet.

Without the written consent of ZS, this product shall not be used in occasions requiring high quality or high reliability, including but not limited to the following occasions: medical equipment, automotive electronics, military facilities and aerospace. ZS shall not be responsible for casualties or property losses caused by abnormal use or application of this product.