



SOT-23 Plastic-Encapsulate Transistors

MMBTA28

FEATURES

- Pá @0~ ||^} d0æ

MARKING: 3SS

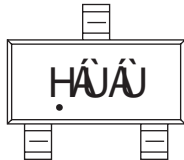

HÚÚÁ Device code
Solid dot = Green molding compound device.

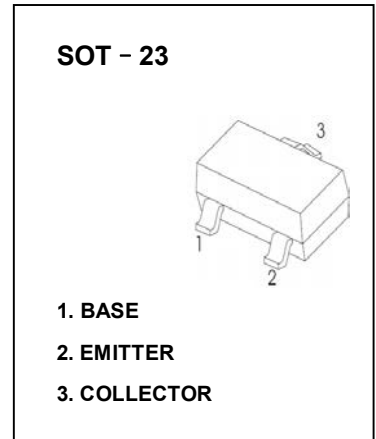

MAXIMUM RATINGS (T_a=25°C unless otherwise noted)

Symbol	Parameter	Value	Unit
V _{CB0}	Ô[^&f ÉÖæ^ÁX æ^Á	ì €Á	XÁ
V _{CE0}	Ô[^&f ÉÖ æ^ÁX æ^Á	ì €Á	XÁ
V _{EB0}	Ô[æ^ÁÉÖæ^ÁX æ^Á	FGÁ	XÁ
I _c	Ô[^&f ÁÖ~ ^} dÁ	í €€Á	{ dÁ
P _c	Ô[^&f ÁÚ , ^ ÁÖã•q æq} Á	G€€Á	{ Y Á
R _{θJA}	V@!{ æÁÚ•ã æ&ÁÚ { ÁR } &q} Á ÁÉ æã} dÁ	î G Á	°C BY Á
T _J , T _{stg}	Operation Junction and Storage Temperature RangeÁ	È í ~ÉFí €	°C

Equivalent Circuit

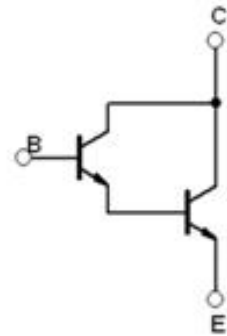

ELECTRICAL CHARACTERISTICS (T_a=25°C unless otherwise specified)

Parameter	Symbol	Test conditions	Min	Typ	Max	Unit
Collector-base breakdown voltage	X _{gúúóuÁ}	QMFÉqúÉQMEÁ	ì €Á			XÁ
Collector-emitter sustain voltage	X _{óúg•d}	QMFÉqúÉXóóMEÁ	ì €Á			XÁ
Emitter-base breakdown voltage	X _{gúúóuÁ}	QMFÉqúÉQMEÁ	FGÁ			XÁ
Collector cut-off current	Q _{óuÁ}	X _{óóM} ÉXÉQMEÁ			€FÁ	μdÁ
Collector cut-off current	Q _{óuÁ}	X _{óóM} ÉXÉXóóMEÁ			€F Á	μdÁ
Emitter cut-off current	Q _{óuÁ}	X _{óóM} ÉXÉQMEÁ			€FÁ	μdÁ
DC current gain	@ _{ógr} ÉÁ	X _{óóM} XÉQMFÉ{ dÁ	F€Á			SÁ
	@ _{ógr} ÉÁ	X _{óóM} XÉQMFÉ{ dÁ	F€Á			SÁ
Collector-emitter saturation voltage	X _{óóg æúF} ÉÁ	QMFÉ{ dÁQMFÉ{ dÁ			F€GÁ	XÁ
	X _{óóg æúF} ÉÁ	QMFÉ{ dÁQMFÉ{ dÁ			F€F Á	XÁ
Base-emitter voltage	X _{óóE}	X _{óóM} XÉQMFÉ{ dÁ			GÁ	XÁ
Collector output capacitance	Ô _{íáÁ}	X _{óóM} FXÉQMFÉ{ dÁ			ì Á] dÁ
Transition frequency	~Á	X _{óóM} XÉQMFÉ{ dÁ				
		-MFÉET P: Á	FG Á			TP: Á

EU~|•Á•dÁ~|•Á æóúHEE •Éã c Á&ÁmGÉÁ È

Typical Characteristics

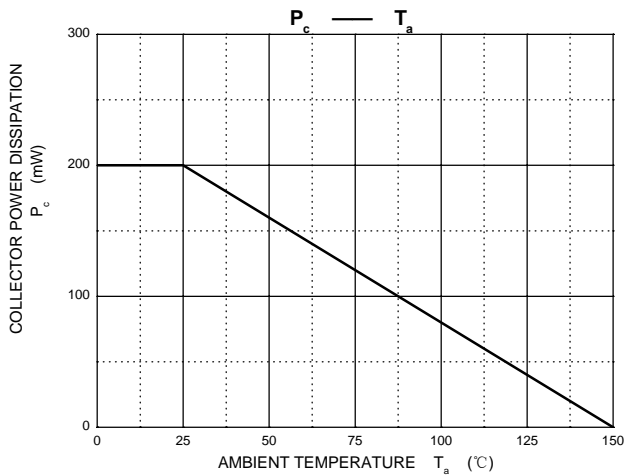
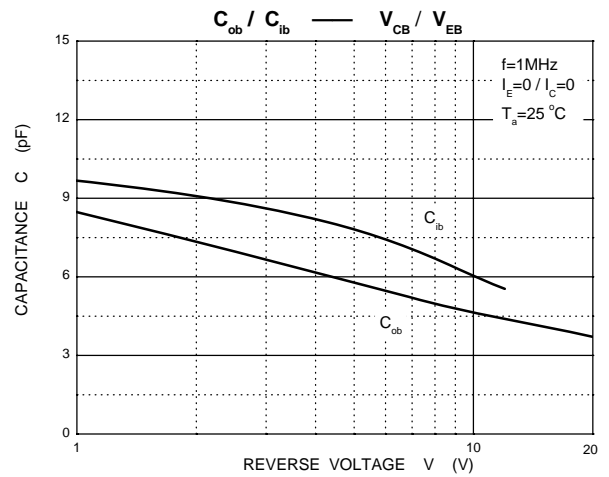
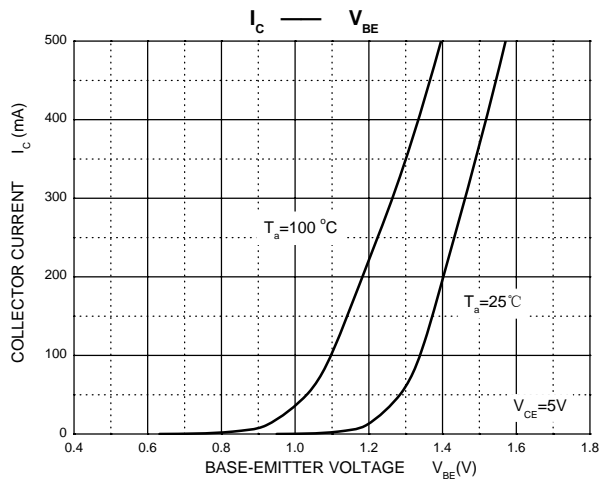
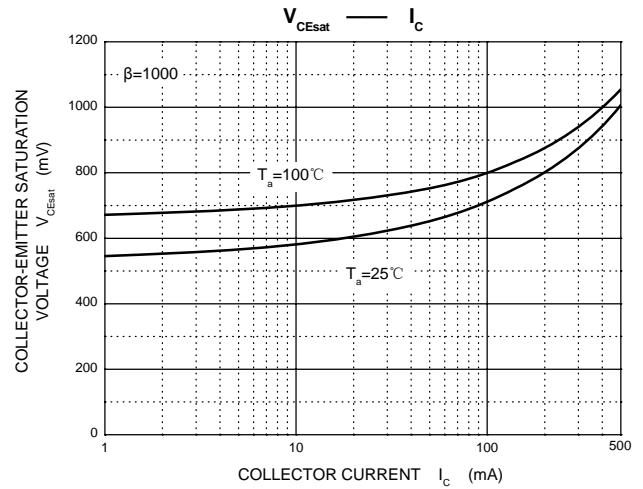
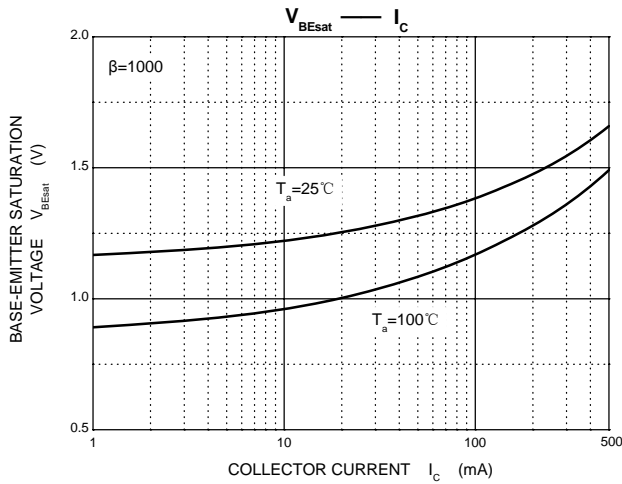
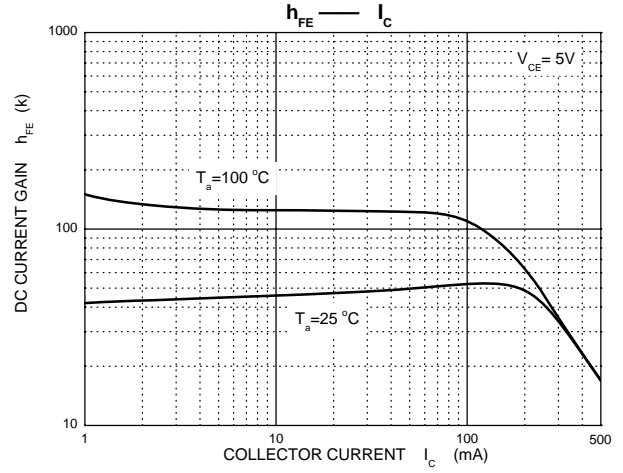
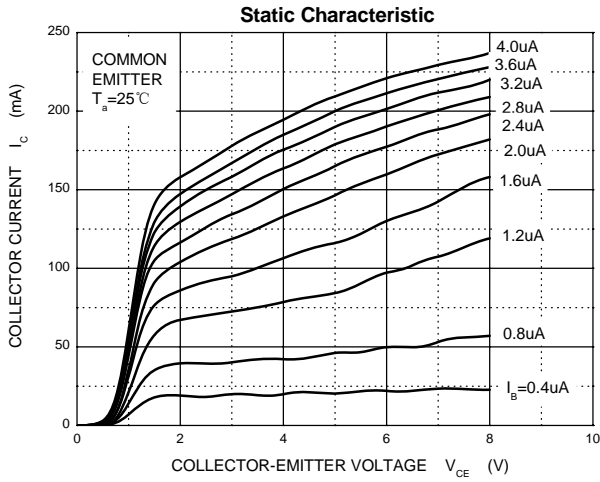

SOT-23 Package Outline Dimensions

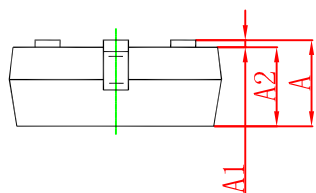
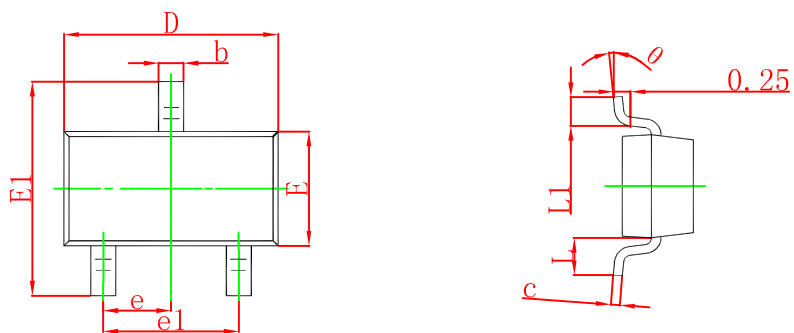

Symbol	Dimensions In Millimeters		Dimensions In Inches	
	Min	Max	Min	Max
A	0.900	1.150	0.035	0.045
A1	0.000	0.100	0.000	0.004
A2	0.900	1.050	0.035	0.041
b	0.300	0.500	0.012	0.020
c	0.080	0.150	0.003	0.006
D	2.800	3.000	0.110	0.118
E	1.200	1.400	0.047	0.055
E1	2.250	2.550	0.089	0.100
e	0.950 TYP		0.037 TYP	
e1	1.800	2.000	0.071	0.079
L	0.550 REF		0.022 REF	
L1	0.300	0.500	0.012	0.020
θ	0°	8°	0°	6°

SOT-23 Suggested Pad Layout

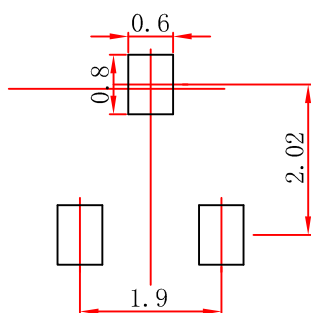

- Note:
1. Controlling dimension: in millimeters.
 2. General tolerance: ± 0.05 mm.
 3. The pad layout is for reference purposes only.

SOT-23 Tape and Reel

SOT-23 Embossed Carrier Tape

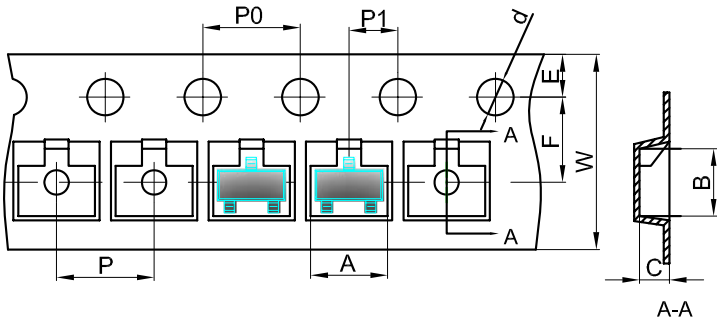

Packaging Description:
 SOT-23 parts are shipped in tape. The carrier tape is made from a dissipative (carbon filled) polycarbonate resin. The cover tape is a multilayer film (Heat Activated Adhesive in nature) primarily composed of polyester film, adhesive layer, sealant, and anti-static sprayed agent. These reeled parts in standard option are shipped with 3,000 units per 7" or 17.8cm diameter reel. The reels are clear in color and is made of polystyrene plastic (anti-static coated).

Dimensions are in millimeter										
Pkg type	A	B	C	d	E	F	P0	P	P1	W
SOT-23	3.15	2.77	1.22	Ø1.50	1.75	3.50	4.00	4.00	2.00	8.00
(Tolerance)	+/-0.1	+/-0.1	+/-0.1	+/-0.1	+/-0.1	+/-0.1	+/-0.1	+/-0.1	+/-0.1	+0.3/-0.1

SOT-23 Tape Leader and Trailer

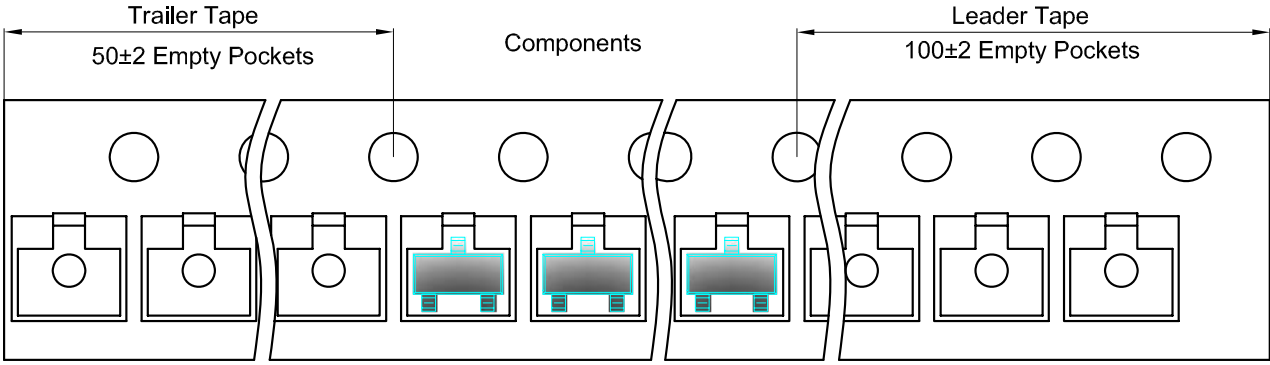

SOT-23 Reel

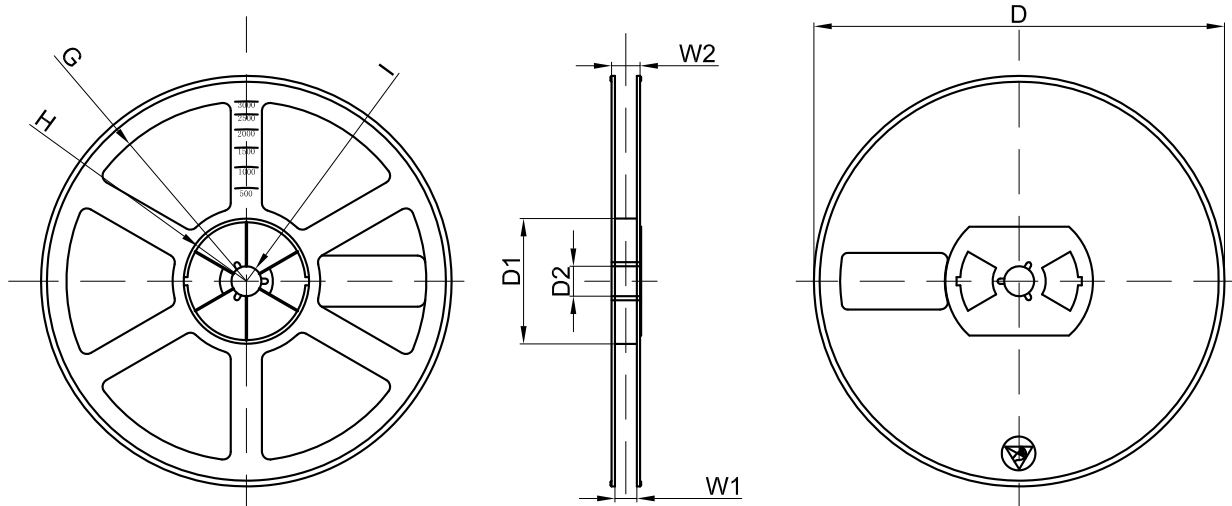

Dimensions are in millimeter								
Reel Option	D	D1	D2	G	H	I	W1	W2
7"Dia	Ø178.00	54.40	13.00	R78.00	R25.60	R6.50	9.50	12.30
Tolerance	+/-2	+/-1	+/-1	+/-1	+/-1	+/-1	+/-1	+/-1

REEL	Reel Size	Box	Box Size(mm)	Carton	Carton Size(mm)	G.W.(kg)
3000 pcs	7 inch	45,000 pcs	203×203×195	180,000 pcs	438×438×220	