

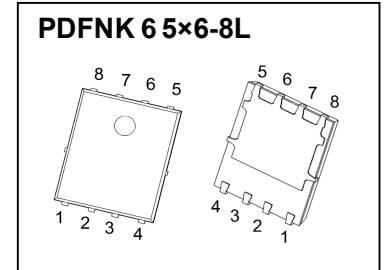

PDFNK 6 5×6-8L Plastic-Encapsulate MOSFETS

AC65SN10 N-Channel Power MOSFET

$V_{(BR)DSS}$	$R_{DS(on)TYP}$	I_D
FEX	9.0 (OFEX	IICE
	FGZ (OIEEX	



DESCRIPTION

AC65SN10 is a N-channel power MOSFET with a plastic encapsulation. It is designed for high power applications and is suitable for use in a wide range of power electronics circuits.

FEATURES

- High power capability
- Low on-state resistance
- High switching speed
- Low gate charge
- High thermal conductivity
- Wide operating temperature range

APPLICATIONS

- Power MOSFETs for power electronics
- Power MOSFETs for power electronics

MARKING

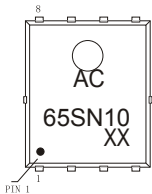

AC65SN10 MÚ...
 Ú...
 Y... M...

EQUIVALENT CIRCUIT

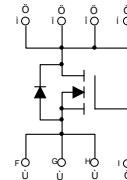

ABSOLUTE MAXIMUM RATINGS (T_a=25°C unless otherwise noted)

Parameter	Symbol	Value	Unit
Drain-Source Voltage	V _{DS}	100	V
Gate-Source Voltage	V _{GS}	±20	V
Continuous Drain Current	I _D ^①	65	A
Pulsed Drain Current	I _{DM} ^②	200	A
Single Pulsed Avalanche Energy	E _{AS} ^③	80	mJ
Maximum Power Dissipation	P _D ^①	88	W
Thermal Resistance from Junction to Ambient	R _{θJA} ^⑥	62.5	°C/W
Thermal Resistance from Junction to Case	R _{θJC} ^①	1.42	°C/W
Operating Junction and Storage Temperature Range	T _J , T _{stg}	-55~+150	°C

MOSFET ELECTRICAL CHARACTERISTICS

$T_a=25^\circ\text{C}$ unless otherwise specified

Parameter	Symbol	Test Condition	Min	Typ	Max	Unit
Off characteristics						
Drain-source breakdown voltage	$V_{(BR)DSS}$	$V_{GS} = 0V, I_D = 250\mu A$	100			V
Zero gate voltage drain current	I_{DSS}	$V_{DS} = 80V, V_{GS} = 0V$	$T_J = 25^\circ\text{C}$		1.0	μA
			$T_J = 125^\circ\text{C}$		100	
Gate-body leakage current	I_{GSS}	$V_{DS} = 0V, V_{GS} = \pm 20V$			± 100	nA
On characteristics ^④						
Gate-threshold voltage	$V_{GS(th)}$	$V_{DS} = V_{GS}, I_D = 250\mu A$	1.0	2.0	2.5	V
Static drain-source on-state resistance	$R_{DS(on)}$	$V_{GS} = 10V, I_D = 10A$		9.0	11	$m\Omega$
		$V_{GS} = 4.5V, I_D = 10A$		12.2	17	$m\Omega$
Dynamic characteristics ^{④ ⑤}						
Input capacitance	C_{iss}	$V_{DS} = 50V, V_{GS} = 0V, f = 100\text{KHz}$		1650	3300	pF
Output capacitance	C_{oss}			279	558	
Reverse transfer capacitance	C_{rss}			4.8	9.6	
Gate resistance	R_g	$f = 1\text{MHz}$		2.2		Ω
Switching characteristics ^{④ ⑤}						
Total gate charge	Q_g	$V_{GS} = 10V, V_{DS} = 50V, I_D = 20A$		27	54	nC
Gate-source charge	Q_{gs}			3.0	6	
Gate-drain charge	Q_{gd}			5.1	10.2	
Turn-on delay time	$t_{d(on)}$	$V_{DS} = 50V, I_D = 20A, V_{GS} = 10V, R_G = 2.2\Omega$		8		ns
Turn-on rise time	t_r			4.2		
Turn-off delay time	$t_{d(off)}$			20		
Turn-off fall time	t_f			4.0		
Drain-Source Diode Characteristics						
Drain-source diode forward voltage	V_{SD} ^④	$V_{GS} = 0V, I_S = 20A$			1.2	V
Continuous drain-source diode forward current	I_S ^①				65	A
Pulsed drain-source diode forward current	I_{SM} ^②				200	A

Ⓜ [0.1A

1. $T_c = 25^\circ\text{C}$ Limited only by maximum temperature allowed.

2. $P_w \leq 10\mu s$, Duty cycle $\leq 1\%$.

3. EAS condition: $V_{DD} = 50V, V_{GS} = 10V, L = 0.3\text{mH}, R_g = 25\Omega$ Starting $T_J = 25^\circ\text{C}$.

4. Pulse Test : Pulse Width $\leq 300\mu s$, duty cycle $\leq 2\%$.

5. Guaranteed by design, not subject to production.

6. The value of $R_{\theta JA}$ is measured with the device mounted on 1 in 2 FR-4 board with 2oz. Copper, in a still air environment with $T_a = 25^\circ\text{C}$.

Typical Characteristics

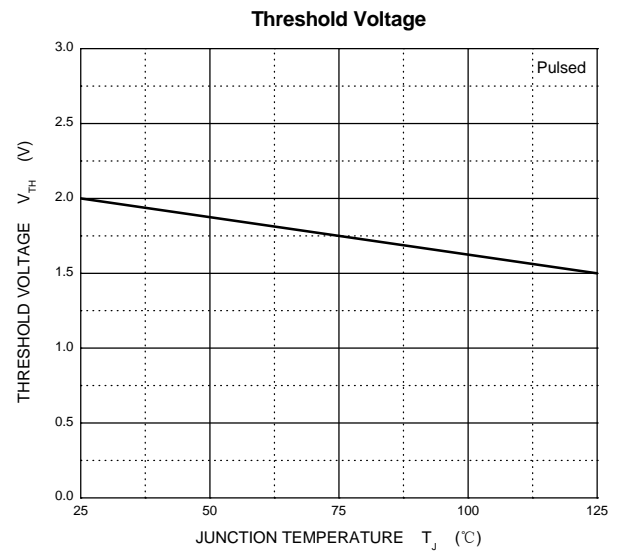
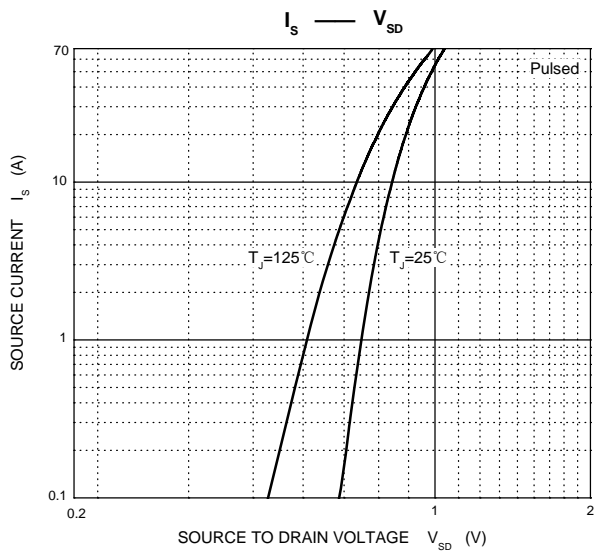
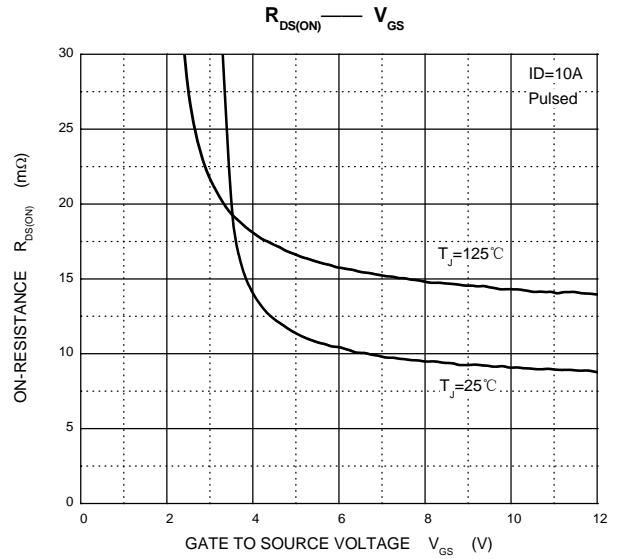
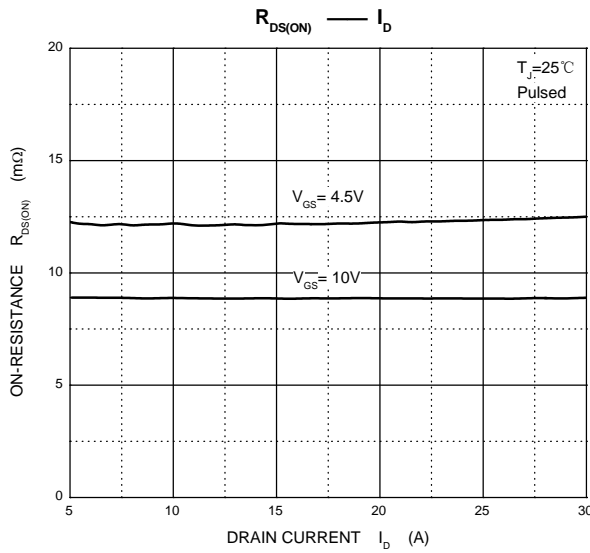
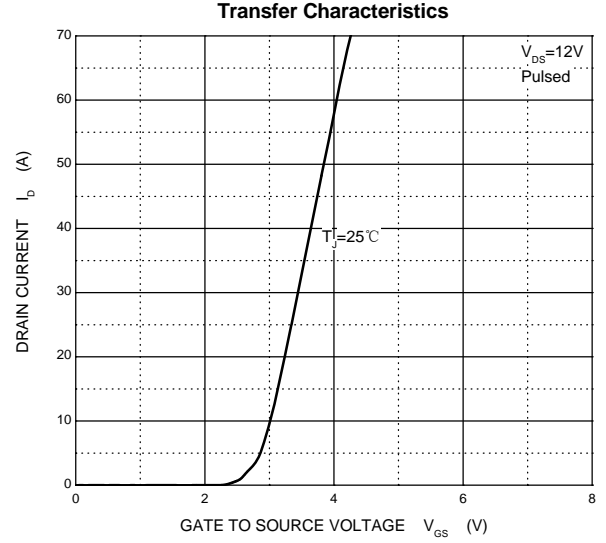
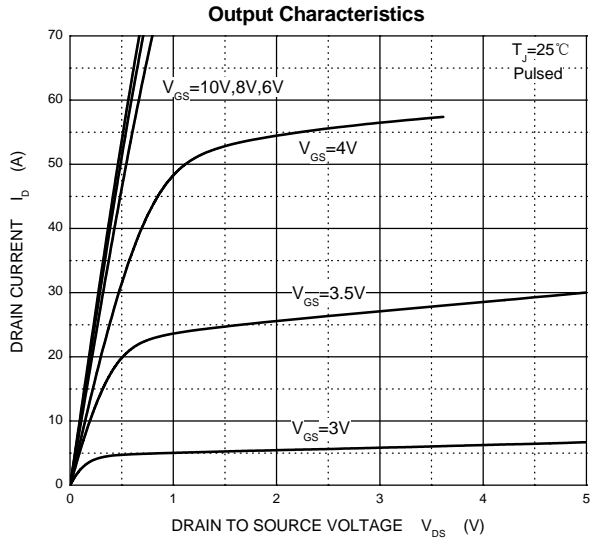

Typical Characteristics

Capacitances

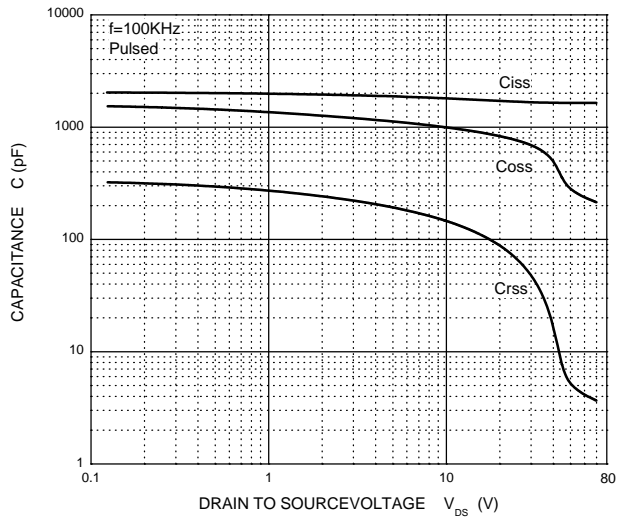

Gate Charge

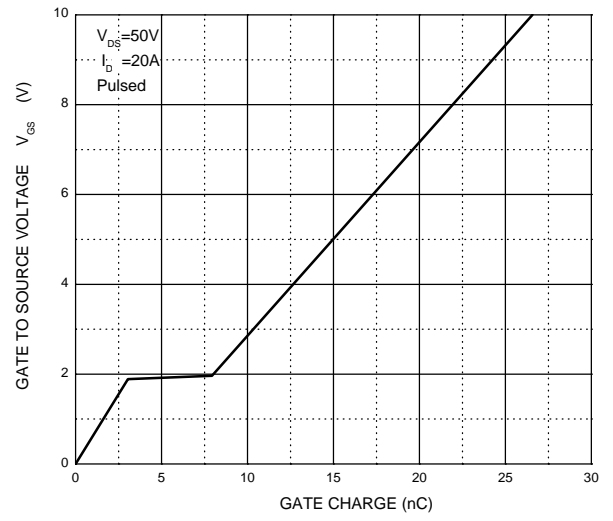

PDFNWB5x6-8L Package Outline Dimensions

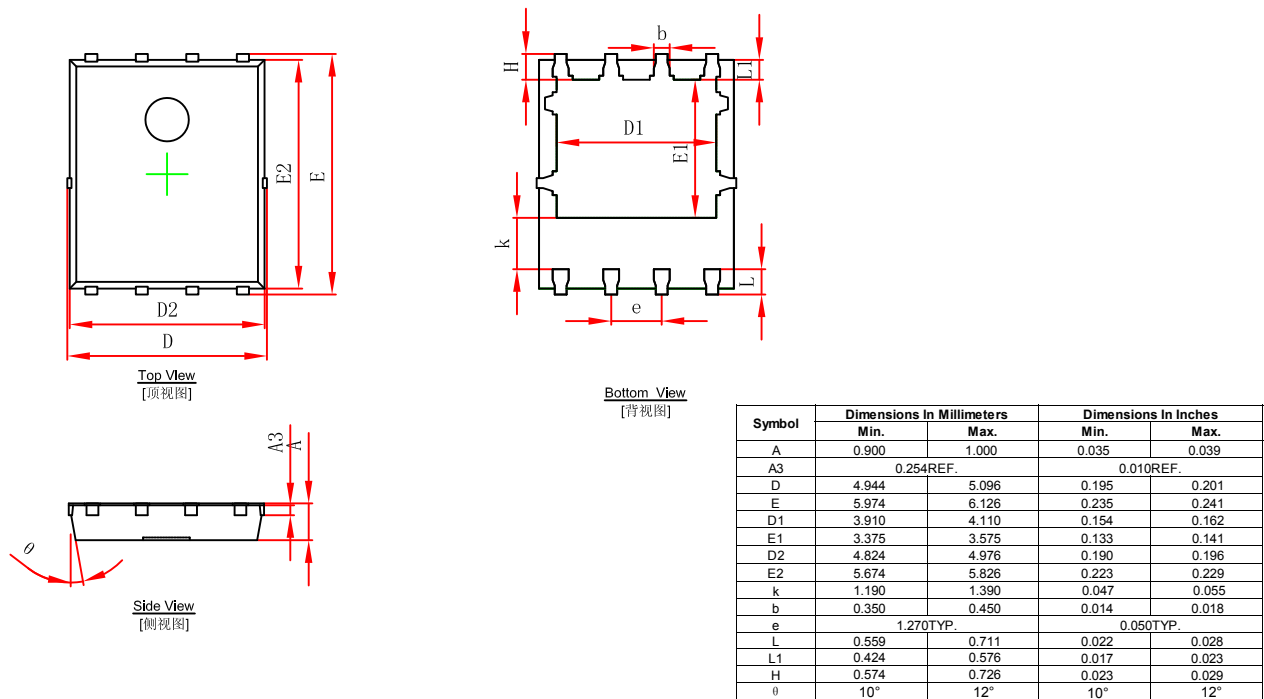

PDFNWB5x6-8L Suggested Pad Layout

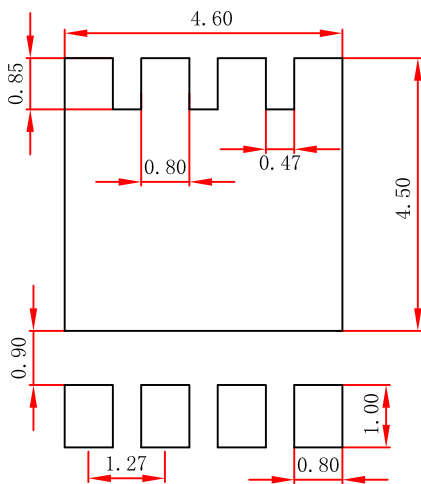

Note:

1. Controlling dimension: in millimeters.
2. General tolerance: ± 0.05 mm.
3. The pad layout is for reference purposes only.

PDFNWB5×6 Tape and Reel

PDFNWB5×6-8L Embossed Carrier Tape

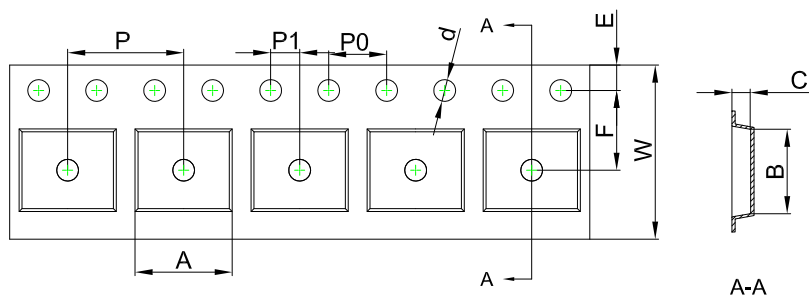

Packaging Description:
PDFNWB5×6-8L parts are shipped in tape. The carrier tape is made from a dissipative (carbon filled) polycarbonate resin. The cover tape is a multilayer film (Heat Activated Adhesive in nature) primarily composed of polyester film, adhesive layer, sealant, and anti-static sprayed agent. These reeled parts in standard option are shipped with 5,000 units per 13" or 33.0 cm diameter reel. The reels are clear in color and is made of polystyrene plastic (anti-static coated).

Dimensions are in millimeter										
Pkg type	A	B	C	d	E	F	P0	P	P1	W
PDFNWB5×6-8L	6.30	5.30	1.10	Ø1.50	1.75	5.50	4.00	8.00	2.00	12.00

PDFNWB5×6-8L Tape Leader and Trailer

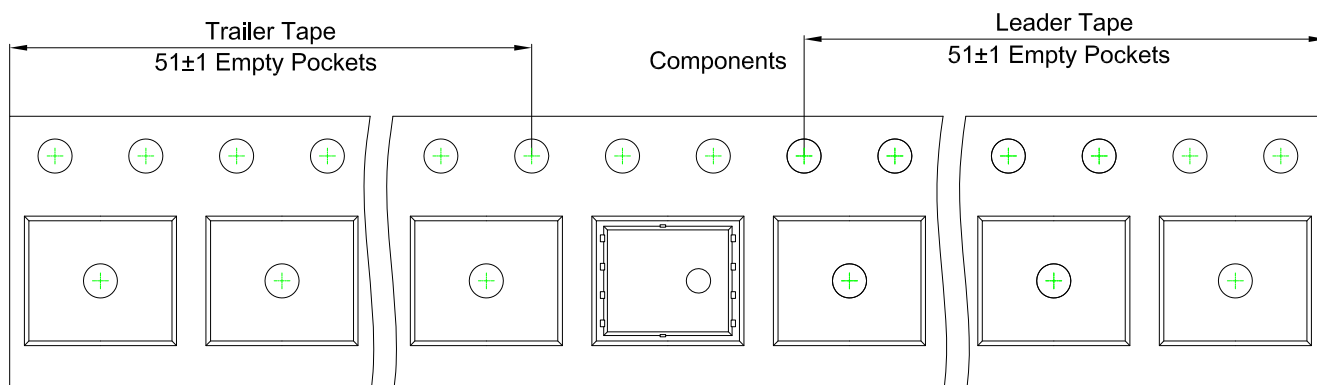

PDFNWB5×6-8L Reel

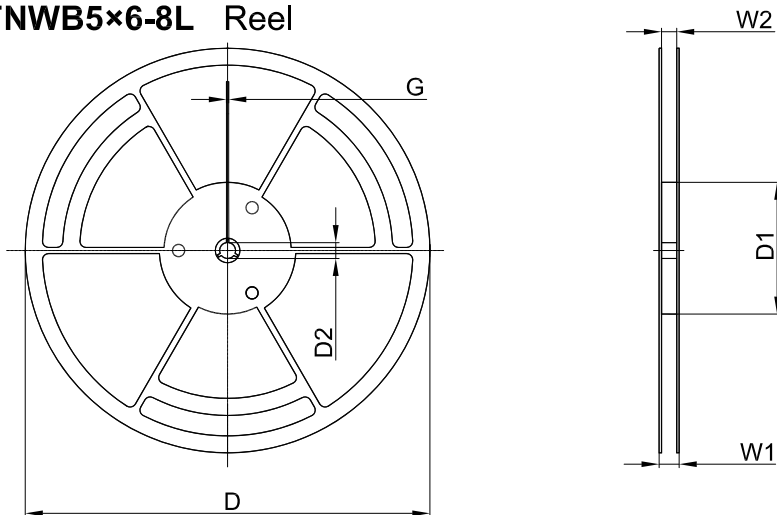

Dimensions are in millimeter						
Reel Option	D	D1	D2	G	W1	W2
13"Dia	Ø330.00	100.00	13.00	1.90	17.60	12.40

REEL	Reel Size	Box	Box Size(mm)	Carton	Carton Size(mm)
5,000 pcs	13 inch	5,000 pcs	340×336×29	50,000 pcs	353×346×365